

Dawlace
ریلائبل ہے!

Dawlace

Before using your Dawlace air conditioner, please read this manual carefully and keep it for future reference.

FLOOR STANDING AIR CONDITIONER INSTRUCTION MANUAL

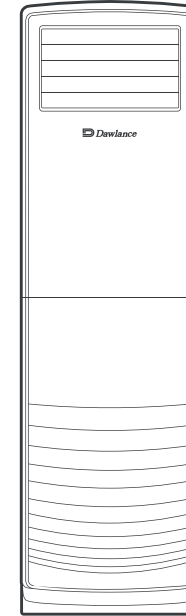

Model#
GLAMOUR INVERTER 45 FS

Read This Manual

Keep this manual where the operator can easily find it. Inside you will find many helpful hints on how to use and maintain your air conditioner properly. Just a little preventative care on your part can save you a great deal of time and money over the life of your air conditioner. You'll find many answers to common problems in the chart of Troubleshooting Tips. If you review the chart of Troubleshooting Tips first, you may not need to call for service.

SERIAL NO.

CONTENTS

SAFETY PRECAUTIONS	1
NAMES OF PARTS	4
INDOOR UNIT DISPLAY	5
INDOOR UNIT CONTROL PANEL	7
REMOTE CONTROLLER	8
OPERATING INSTRUCTIONS	12
PROTECTION	18
INSTALLATION MANUAL.....	19
MAINTENANCE	28
TROUBLESHOOTING	29

In line with the company's policy of continual product improvement, the aesthetic and dimensional characteristics, technical data and accessories of this appliance may be changed without notice.

SAFETY RULES AND RECOMMENDATIONS FOR THE INSTALLER

⚠ Read this guide before installing and using the appliance.

⚠ During the installation of the indoor and outdoor units the access to the working area should be forbidden to children. Unforeseeable accidents could happen.

⚠ Make sure that the base of the outdoor unit is firmly fixed.

⚠ Check that air cannot enter the refrigerant system and check for refrigerant leaks when moving the air conditioner.

⚠ Carry out a test cycle after installing the air conditioner and record the operating data.

⚠ The ratings of the fuse installed in the built-in control unit are T 5A / 250V .

⚠ The user must protect the indoor unit with a fuse of suitable capacity for the maximum input current or with another overload protection device.

⚠ Ensure that the mains voltage corresponds to that stamped on the rating plate . Keep the switch or power plug clean. Insert the power plug correctly and firmly into the socket, thereby avoiding the risk of electric shock or fire due to insufficient contact.

⚠ Check that the socket is suitable for the plug , otherwise have the socket changed.

⚠ The appliance must be fitted with means for disconnection from the supply mains having a contact separation in all poles that provide full disconnection under overvoltage category III conditions, and these means must be incorporated in the fixed wiring in accordance with the wiring rules.

⚠ The air conditioner must be installed by professional or qualified persons.

⚠ Do not install the appliance at a distance of less than 50 cm from inflammable substances (alcohol, etc.) Or from pressurised containers (e.g. spray cans).

⚠ If the appliance is used in areas without the possibility of ventilation, precautions must be taken to prevent any leaks of refrigerant gas from remaining in the environment and creating a danger of fire

⚠ The packaging materials are recyclable and should be disposed of in the separate waste bins .Take the air conditioner at the end of its useful life to a special waste collection centre for disposal.

⚠ Only use the air conditioner as instructed in this booklet . These instructions are not intended to cover every possible condition and situation . As with any electrical household appliance , common sense and caution are therefore always recommended for installation, operation and maintenance.

⚠ The appliance must be installed in accordance with applicable national regulations.

⚠ Before accessing the terminals , all the power circuits must be disconnected from the power supply.

⚠ The appliance shall be installed in accordance with national wiring regulations.

⚠ This appliance can be used by children aged from 8 years and above and persons with reduced physical, sensory or mental capabilities or lack of experience and knowledge if they have been given supervision or instruction concerning use of the appliance in a safe way and understand the hazards involved. Children shall not play with the appliance. Cleaning and user maintenance shall not be made by children without supervision.

SAFETY RULES AND RECOMMENDATIONS FOR THE USER

- ⚠ Do not try to install the conditioner alone; always contact specialized technical personnel.
- ⚠ Cleaning and maintenance must be carried out by specialised technical personnel. In any case disconnect the appliance from the mains electricity supply before carrying out any cleaning or maintenance.
- ⚠ Ensure that the mains voltage corresponds to that stamped on the rating plate. Keep the switch or power plug clean. Insert the power plug correctly and firmly into the socket, thereby avoiding the risk of electric shock or fire due to insufficient contact.
- ⚠ Do not pull out the plug to switch off the appliance when it is in operation, since this could create a spark and cause a fire, etc.
- ⚠ This appliance has been made for air conditioning domestic environments and must not be used for any other purpose, such as for drying clothes, cooling food, etc.
- ⚠ The packaging materials are recyclable and should be disposed of in the separate waste bins. Take the air conditioner at the end of its useful life to a special waste collection centre for disposal.
- ⚠ Always use the appliance with the air filter mounted. The use of the conditioner without air filter could cause an excessive accumulation of dust or waste on the inner parts of the device with possible subsequent failures.
- ⚠ The user is responsible for having the appliance installed by a qualified technician, who must check that it is earthed in accordance with current legislation and insert a thermomagnetic circuit breaker.
- ⚠ The batteries in remote controller must be recycled or disposed of properly. Disposal of Scrap Batteries --- Please discard the batteries as sorted municipal waste at the accessible collection point.
- ⚠ Never remain directly exposed to the flow of cold air for a long time. The direct and prolonged exposition to cold air could be dangerous for your health. Particular care should be taken in the rooms where there are children, old or sick people.
- ⚠ If the appliance gives off smoke or there is a smell of burning, immediately cut off the power supply and contact the Service Centre.
- ⚠ The prolonged use of the device in such conditions could cause fire or electrocution.
- ⚠ Have repairs carried out only by an authorised Service Centre of the manufacturer. Incorrect repair could expose the user to the risk of electric shock, etc.
- ⚠ Unhook the automatic switch if you foresee not to use the device for a long time. The airflow direction must be properly adjusted.
- ⚠ The flaps must be directed downwards in the heating mode and upwards in the cooling mode.
- ⚠ Only use the air conditioner as instructed in this booklet. These instructions are not intended to cover every possible condition and situation. As with any electrical household appliance, common sense and caution are therefore always recommended for installation, operation and maintenance.
- ⚠ Ensure that the appliance is disconnected from the power supply when it will remain inoperative for a long period and before carrying out any cleaning or maintenance.
- ⚠ Selecting the most suitable temperature can prevent damage to the appliance.

SAFETY RULES AND PROHIBITIONS

- ⊖ Do not bend , tug or compress the power cord since this could damage it. Electrical shocks or fire are probably due to a damaged power cord. Specialised technical personnel only must replace a damaged power cord.
- ⊖ Do not use extensions or gang modules.
- ⊖ Do not touch the appliance when barefoot or parts of the body are wet or damp.
- ⊖ Do not obstruct the air inlet or outlet of the indoor or the outdoor unit.
The obstruction of these openings causes a reduction in the operative efficiency of the conditioner with possible consequent failures or damages.
- ⊖ In no way alter the characteristics of the appliance.
- ⊖ Do not install the appliance in environments where the air could contain gas , oil or sulphur or near sources of heat.
- ⊖ This appliance is not intended for use by persons (including children) with reduced physical, sensory or mental capabilities, or lack of experience and knowledge, unless they have been given supervision or instruction concerning use of the appliance by a person responsible for their safety.
- ⊖ Do not climb onto or place any heavy or hot objects on top of the appliance.
- ⊖ Do not leave windows or doors open for long when the air conditioner is operating.
- ⊖ Do not direct the airflow onto plants or animals.
- ⊖ A long direct exposition to the flow of cold air of the conditioner could have negative effects on plants and animals.
- ⊖ Do not put the conditioner in contact with water.
The electrical insulation could be damaged and thus causing electrocution.
- ⊖ Do not climb onto or place any objects on the outdoor unit
- ⊖ Never insert a stick or similar object into the appliance. It could cause injury.
- ⊖ Children should be supervised to ensure that they do not play with the appliance. If the supply cord is damaged, it must be replaced by the manufacturer, its service agent or similarly qualified persons in order to avoid a hazard.

NAMES OF THE PARTS

INDOOR UNIT

No.	Description
1	Airflow direction flaps
2	Deflectors
3	Indoor unit rating label
4	LED Display
5	Touch panel
6	Front panel
7	Air filter
8	Front panel
9	Remote controller

INDOOR UNIT

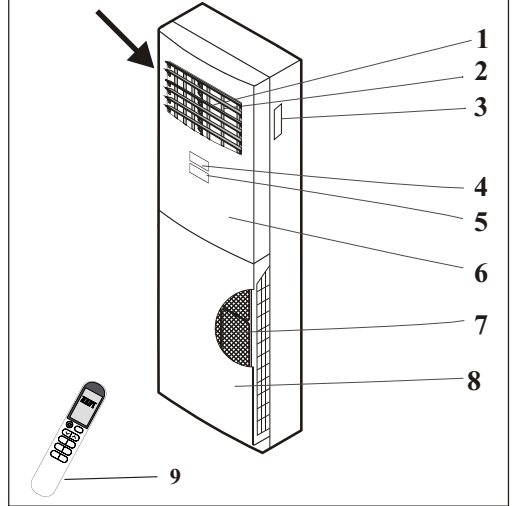

OUTDOOR UNIT

No.	Description
11	Air outlet grille
12	Outdoor unit rating label
13	Terminal block cover
14	Gas valve
15	liquid valve

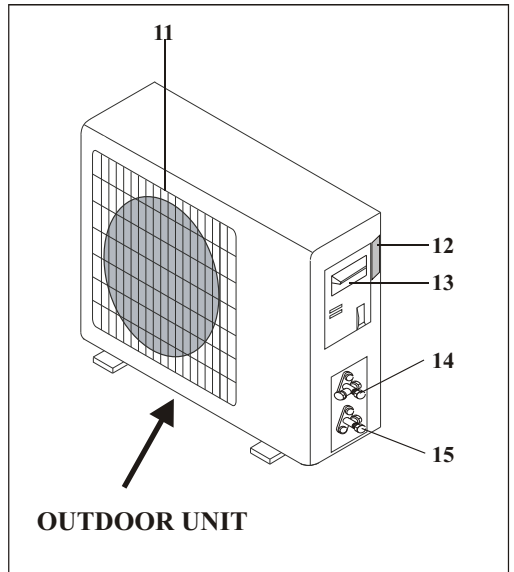

Note: the above figures are only intended to be a simple diagram of the appliance and may not correspond to the appearance of the units that have been purchased.

INDOOR UNIT DISPLAY

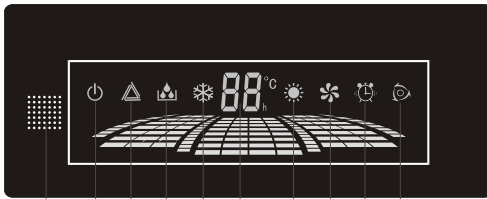

Signal
receptor

1 2 3 4 5 6 7 8 9

4 3 5 7 6

Signal
receptor

2 4 6 17 8 18 10 11



7 3 16 15 5 8 14-13-12



The shape and position of indicators may vary according to the model, but their functions are the same.

No.	Led	Function
1		Shows that the unit is powered
2		FEEL mode indicator
3		DEHUMIDIFYING indicator
4		COOLING indicator
5		Indicates the set temperature in °C or ° F or time in Hour
6		HEATING indicator, flashes in defrost circle and Anti-Cold Air function,
7		FAN ONLY OPERATION indicator
8		TIMER mode
9		HEALTHY indicator
10		ECO indicator
11		SUPER indicator
12		HIGH FAN SPEED indicator
13		MIDDLE FAN SPEED indicator
14		LOW FAN SPEED indicator
15		“FLAP” SWING indicator
16		SLEEP indicator
17		DEFLECTORS SWING indicator
18		ANTI-MILDEW indicator

INDOOR UNIT DISPLAY

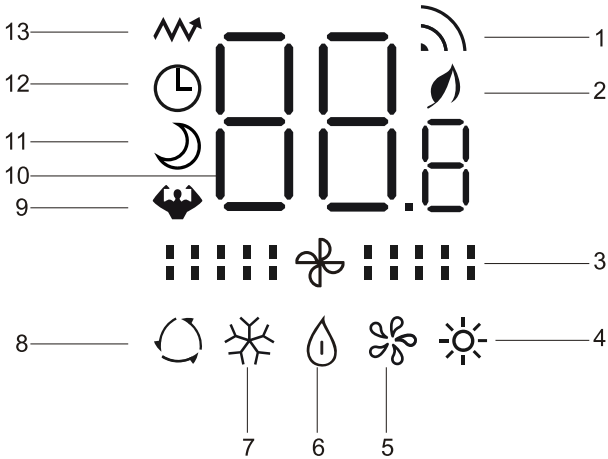

⚠ The shape and position of indicators may vary according to the model, but their function is the same.

No.	Led	Function
1		WiFi indicator(Optional)
2		HEALTHY indicator
3		FAN SPEED indicator
4		HEATING indicator , flashes in defrost circle and Anti-Cold Air function.
5		FAN ONLY OPERATION indicator
6		DEHUMIDIFYING indicator
7		COOLING indicator
8		FEEL mode indicator
9		TURBO indicator
10		Indicates the set temperature in °C or ° For time in Hour
11		SLEEP indicator
12		TIMER indicator
13		Electric heater indicator(need to reserve)

INDOOR UNIT CONTROL PANEL

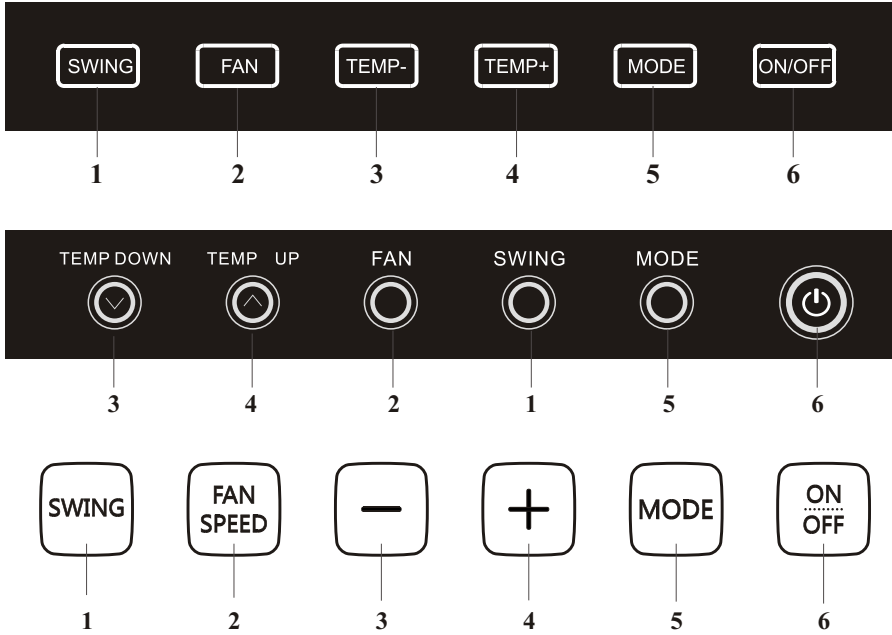









No.	Button	Function
1	SWING	To activate or deactivate of the movement of the “Flaps” and deflectors .
2	FAN	To select the fan speed of auto/low/mid/high
3	TEMP-	Decrease the temperature or time by 1 unit
4	TEMP+	Increase the temperature or time by 1 unit
5	MODE	To select the mode of operation
6	ON/OFF	To switch the conditioner on and off.
7	COMPOSITE BUTTON	Keep pressing the SWING button on the control panel for 3 seconds (two beeps), then press the button "TEMP UP" activates the "flaps" the air flow is directed from up to down and press the button "TEMP DOWN" activates the "deflectors" the air flow is directed from rightward or leftward.

 *The shape and position of the button may be different according to the model, but their function is the same.*

Remark: the external static pressure of heat pumps is 0 Pa for all models.

REMOTE CONTROLLER

No.	Button	Function
1		To turn on or off the air conditioner .
2	OPTION	To activate or deactivate optional function(Check below table).
3	∨	To decrease temperature, time setting or choose the function.
4	∧	To increase temperature , time setting or choose the function.
5	GEN	To activate/deactivate the GEN function which enables the unit run in the set current level,cycle as below OFF→L3→L2→L1”
	ECO	Press this button to activate/deactivate the ECO function .
6	TURBO	Press this button to activate/deactivate the Super function which enables the unit to reach the preset temperature in the shortest time.
7	MODE	To select the mode of operation(AUTO COOL DRY FAN HEAT)
8	FAN	To select the fan speed of auto/mute/low/mid-low/mid/mid-high/high/turbo , cycle as below. 
9		To activate the swing of horizontal flap(up/down) or deactivate it.
10		To activate the swing of vertical flap(left/right) or deactivate it.

ON/OFF	Mode	OPTIONS
ON	AUTO	TIMER DISPLAY HEALTH I FEEL 8°C H
	COOL	TIMER DISPLAY HEALTH SLEEP MILDEW I FEEL 8°C H 
	DRY	TIMER DISPLAY HEALTH MILDEW I FEEL 8°C H
	FAN	TIMER DISPLAY HEALTH I FEEL 8°C H
	HEAT	TIMER DISPLAY HEALTH SLEEP I FEEL 8°C H 
OFF	AUTO	CLEAN TIMER DISPLAY HEALTH I FEEL 8°C H
	COOL	CLEAN TIMER DISPLAY HEALTH SLEEP MILDEW I FEEL 8°C H 
	DRY	CLEAN TIMER DISPLAY HEALTH MILDEW I FEEL 8°C H
	FAN	CLEAN TIMER DISPLAY HEALTH I FEEL 8°C H
	HEAT	CLEAN TIMER DISPLAY HEALTH SLEEP I FEEL 8°C H 

 You will hear a beep when you press the following buttons or select the following optional functions, though the actual model haven't this function, we express our apologies:

 (Optional Function: COMFORTABLE COOLING airflow)

HEALTH (Optional Function: generate the ionizer)

 (Optional Function: COMFORTABLE HEATING airflow)

 (button: SWING LEFT/RIGHT)

 (Optional Function: 8°C Heating)

flashing  (Optional Function: Wide-angle air supply)

REMOTE CONTROLLER

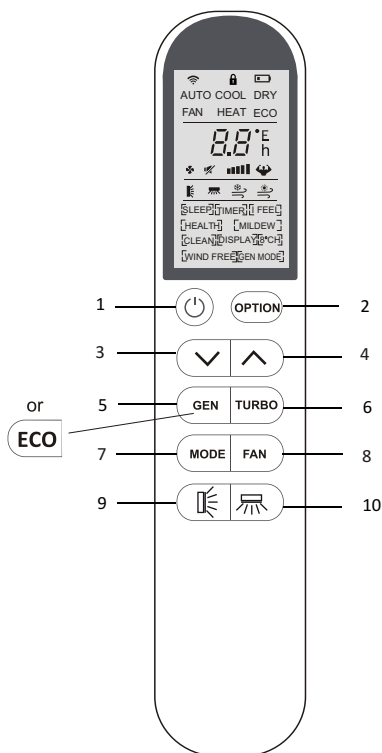

 You will hear a beep when you press the following buttons or select the following optional functions, though the actual model haven't this function, we express our apologies:

 (Optional Function: COMFORTABLE COOLING airflow)

 (Optional Function: COMFORTABLE HEATING airflow)

 (Optional Function: 8°C Heating)

 (Optional Function: generate the ionizer)









 (button: SWING LEFT/RIGHT)

 (Optional Function: Wide-angle air supply)

REMOTE CONTROLLER

Remote controller DISPLAY

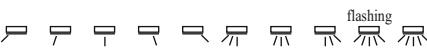
Meaning of symbols on the liquid crystal display

No.	Symbols	Meaning
1		Single indicator
2		Child Lock function indicator
3		Battery indicator
4	AUTO	Mode Auto function indicator
5	COOL	Mode Cooling indicator
6	DRY	Mode Dry indicator
7	FAN	Mode Fan indicator
8	HEAT	Mode Heating indicator
9	ECO	ECO function indicator
10	GEN	GEN function indicator
11	23h [TIMER]	Timer indicator
12	28°C	Temperature indicator
13		Fan speed indicator: Auto/low/mid-low/mid/mid-high/high
14		Mute indicator
15		SUPER indicator
16		Flap swing angle indicator
17		Deflector swing angle indicator
18		Comfortable cooling airflow indicator
19		Comfortable heating airflow indicator
20	[SLEEP] [TIMER] [FEEL] [HEALTH] [MILDEW] [CLEAN] [DISPLAY] [8°C] [WIND FREE] [GEN MODE]	Optional functions indicator

 You will hear a beep when you press the following buttons or select the following optional functions, though the actual model haven't this function, we express our apologies:

 (Optional Function: COMFORTABLE COOLING airflow)

 (Optional Function: generate the ionizer)

 (Optional Function: COMFORTABLE HEATING airflow)

 (button: SWING LEFT/RIGHT)

 (Optional Function: 8°C Heating)

 (Optional Function: Wide-angle air supply)

REMOTE CONTROLLER

Replacement of Batteries

Remove the battery cover plate from the rear of the remote controller, by sliding it in the direction of the arrow.

Install the batteries according the direction (+and -)shown on the Remote Controller.

Reinstall the battery cover by sliding it into place.

- ⚠ Use 2 LRO 3 AAA (1.5V) batteries . Do not use rechargeable batteries . Replace the old batteries with new ones of the same type when the display is no longer legible.

Do not dispose batteries as unsorted municipal waste. Collection of such waste separately for special treatment is necessary.

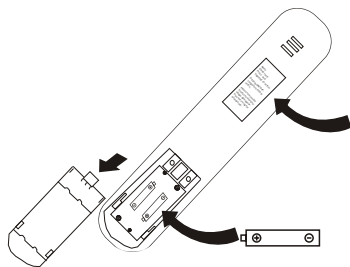

Note
Child-lock: Press \vee and \wedge together to activate.

Display ON/OFF:
Long press ECO button.

Please remove batteries to avoid leakage damage when not using for a long time.

- ⚠ When you insert the batteries for the first time in the remote controller or if you change them, you can program the remote controller of only cooling or cooling and heating.
1. Long press MODE button over 5s to get into the change mode within 3minutes;
 2. Press MODE button to change COOL or HEAT.

NOTE: If you adjust the remote controller in cooling mode, it will not be possible to activate the heating function in units with heating pump . you need to take out the batteries and repeat the procedure described above.

- ⚠ When you insert the batteries for the first time in the remote controller or if you change them, you can program the temperature display switchover function between $^{\circ}\text{C}$ and $^{\circ}\text{F}$.
1. Long press TURBO button over 5s to get into the change mode within 3minutes;
 2. Press TURBO button to change $^{\circ}\text{C}$ and $^{\circ}\text{F}$.

- ⚠
1. Direct the remote controller toward the Air conditioner.
 2. Check that there are no objects between the remote control and the Signal receptor in the indoor unit.
 3. Never leave the remote controller exposed to the rays of the sun.
 4. Keep the remote controller at a distance of at least 1m from the television or other electrical appliances.

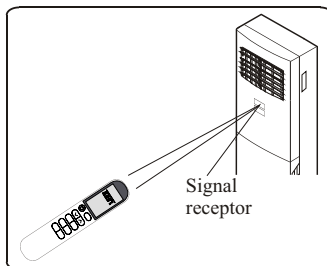



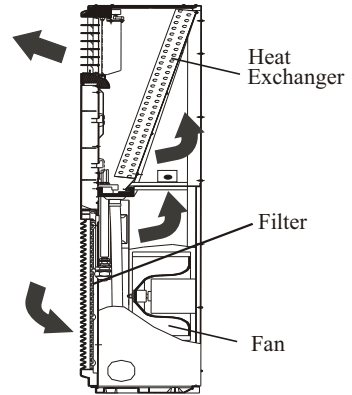

OPERATING INSTRUCTIONS

The air sucked by the fan enters from the grill and passes through the filter, then it is cooled/dehumidified or heated through the heat exchanger.

The direction of the air outlet is motorized up and down by flaps, and manually moved right and left by the vertical deflectors, for some models, the vertical deflectors could be controlled by motor as well.

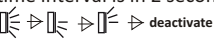
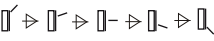

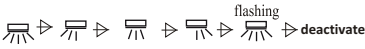

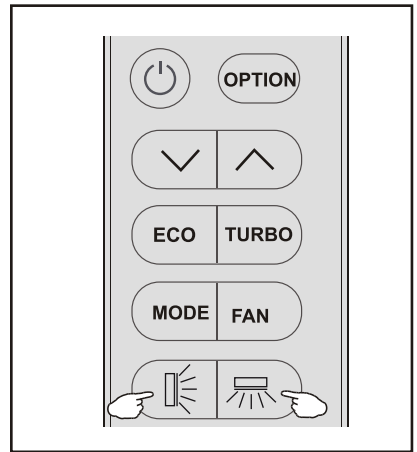

“SWING” CONTROL OF THE AIR FLOW

- Press the button  to activate the “FLAP”,
 - If press time interval is in 2 seconds, the swing will cycle as below:  deactivate
 - If long press the button, the swing angle range of horizontal flap will cycle as below: 
 - If press time interval is over 2 seconds, it will be deactivate the air flow is directed alternatively from up to down .In order to guarantee an even diffusion of the air in the room.
- Press the button  to activates the motorized “deflectors”,
 - If press time interval is in 2 seconds, the swing will cycle as below:  deactivate
 - If long press the button, the swing will cycle as below: 
 - If press time interval is over 2 seconds, it will be deactivate the air flow is directed alternatively from left to right. (Optional function, depends on the models)

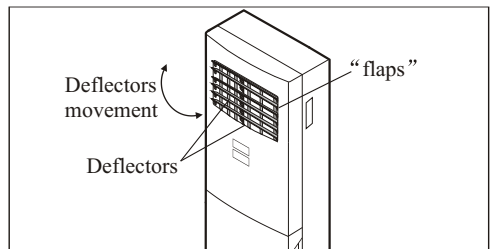

The deflectors are positioned manually and placed under the flaps .They allow to direct the air flow rightward or leftward.



-  This adjustment must be done while the appliance is switched off.
-  Never position “Flaps” manually, the delicate mechanism might seriously damaged!
-  Never poke fingers, sticks or other objects in the air inlet or outlet vents. Such accidental contact with live parts might cause unforeseeable damage or hurt.

MODES OF OPERATION

COOLING MODE

COOL

The cooling function allows the air conditioner to cool the room and at the same time reduces Air humidity.

To activate the cooling function (COOL), press the **MODE** button until the symbol COOL appears on the display.

The cooling function is activated by setting the button ∇ or \blacktriangle at a temperature lower than that of the room.

To optimize the function of the Air conditioner, adjust the temperature (1), the speed (2) and the direction of the air flow (3) by pressing the button indicated.

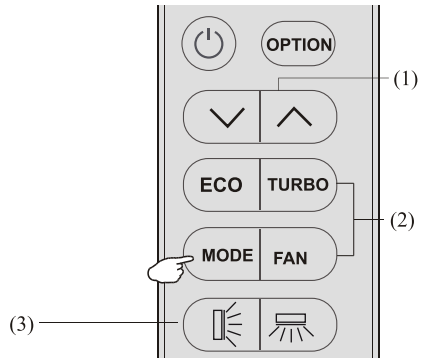

HEATING MODE

HEAT

The heating function allows the air conditioner to heat the room.

To activate the heating function (HEAT), press the **MODE** button until the symbol HEAT appears on the display.

With the button ∇ or \blacktriangle set a temperature higher than that of the room..

To optimize the function of the Air conditioner adjust the temperature (1), the speed (2) and the direction of the air flow (3) by pressing the button indicated



In HEATING operation, the appliance can automatically activate a defrost cycle, which is essential to clean the frost on the condenser so as to recover its heat exchange function. This procedure usually lasts for 2-10 minutes during defrosting, indoor unit fan stop operation. After defrosting, it resumes to HEATING mode automatically.

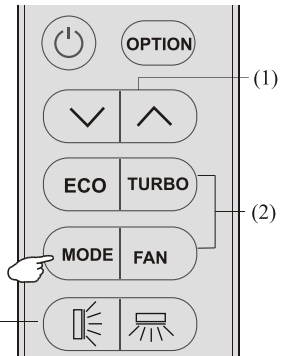

DRY MODE

DRY

This function reduces the humidity of the air to make the room more comfortable.

To set the DRY mode, Press **MODE** until DRY appears in the display. An automatic function of alternating cooling cycles and air fan is activated.

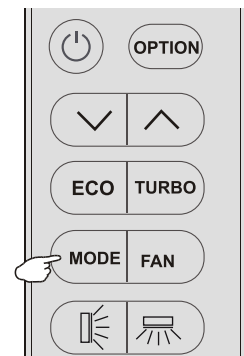

MODES OF OPERATION

FAN MODE(Not FAN button)

FAN

The air conditioner works in only ventilation.

To set the FAN mode, Press **MODE** until FAN appears on the display.

To optimize the function of the air conditioner, adjust the temperature(1), the speed (2) and the direction of the air flow (3) by pressing the buttons indicated.

AUTO MODE

AUTO

Automatic mode.

To activate the AUTO mode of operation, press the **MODE** button on the remote controller until the symbol AUTO appears on the display.

In AUTO mode the run mode will be set automatically according to the room temperature.

To optimize the function of the air conditioner, adjust the temperature(1), the speed (2) and the direction of the air flow (3) by pressing the buttons indicated.

DISPLAY function (Indoor display)

DISPLAY

Switch on/off the LED display on panel

Press **OPTION** at the first time, select the DISPLAY by pressing the button \wedge or \vee until symbol DISPLAY is flashing; Press **OPTION** again to switch off the LED display on the panel, and **DISPLAY** appears on the remote controller display. Do it again to switch on the LED display.

SLEEP function

SLEEP

Press **OPTION** at the first time, select the SLEEP by pressing the button \wedge or \vee until symbol SLEEP is flashing; Press **OPTION** again to activate the SLEEP function, and **SLEEP** appears on the display. Do it again to deactivate this function.

After 10 hours running in sleep mode, the air conditioner will change to the previous setting mode.

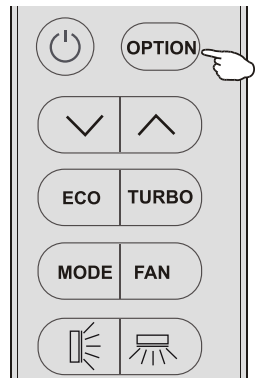
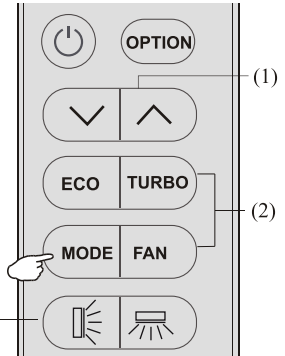

MODES OF OPERATION

GEN function (Optional)

GEN

The air conditioner works in GEN mode

Through GEN mode, you can choose the current level of the unit. There are three levels (L1, L2, L3) in this mode, and the current increases in turn.

To activate GEN function, pressing the button GEN and the unit current level will cycle as below
OFF → L3 → L2 → L1

To cancel this function, press the GEN until code OFF appears on the display.

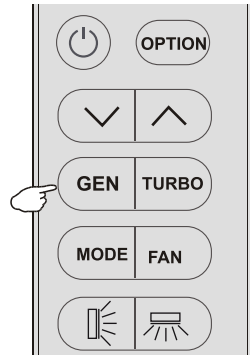

ECO function

ECO

In this mode the appliance automatically sets the operation to achieve energy savings.

1. Press the "ON / OFF" button to turn on appliance and select a COOLING / HEATING mode.
2. Press the "ECO" button, the appliance will run in ECO mode.
3. Pressing the "ECO" button again will cancel the mode, "ECO" will no longer be shown on the LCD screen.

NOTE:

The ECO function is available in COOLING and HEATING modes.

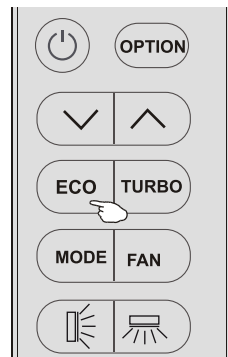

Turbo function



To activate turbo function, pressing the button TURBO or pressing the button FAN until symbol  appears on the display.

To cancel this function, pressing the FAN to switch other fan speed or pressing the TURBO button again.

In AUTO/HEAT/COOL/FAN mode,
When you select TURBO feature, it will use the highest fan setting to blow strong airflow.

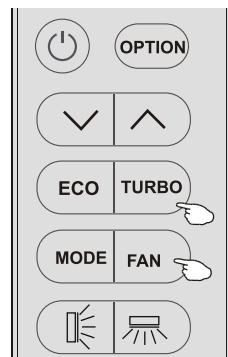

MODES OF OPERATION

TIMER function

 To set the automatic switch-on /off of the air conditioner

Timer setting/change/cancel:

1. Press **OPTION** at the first time , select the Timer by pressing the button \wedge or \vee until symbol **TIMER** is flashing;
2. Press **OPTION** again, the data symbol like $5.5h$ and **TIMER** will be flashing;
3. To set the timer or change the timer:
 - (1) Press the button \wedge or \vee to set the expected timer (Increase or decrease at half-hour intervals) the symbols h and **TIMER** both are flashing.
 - (2) Press **OPTION** or waiting for 5 seconds without any operation to confirm the timer , the pre-setting timer like $5.5h$ and symbol **TIMER** will be on the display.
4. To cancel the timer(if **TIMER** is on)
Repeat step 1, step 2, then press **OPTION** or waiting for 5 seconds without any operation to cancel the timer .

A sample for the Timer-on as Figure1, Timer-off as Figure2

Note:

All processing should be operated in 5 seconds, otherwise the processing will be cancelled.

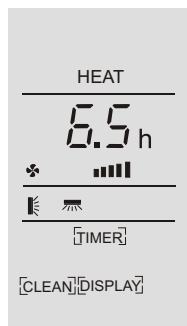
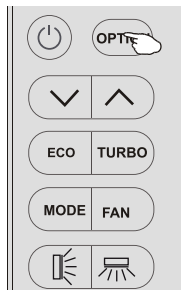

Figure1,Timer-on when switch off

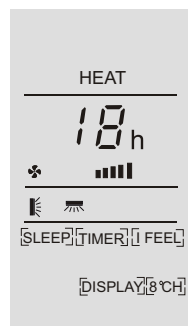



Figure2,Timer-off when switch on

I FEEL function (Optional)



Press **OPTION** at the first time , select the I FEEL by pressing the button \wedge or \vee until symbol I FEEL is flashing; Press **OPTION** again to activate the I FEEL function, and  appears on the display. Do it again to deactivate this function.

This function enable the remote control to measure the temperature at its current location and send this signal 7 times in 2 hours to the air conditioner to enable the air conditioner to optimize the temperature around you and ensure maximum comfort.

It will automatically deactivate 2 hours later.

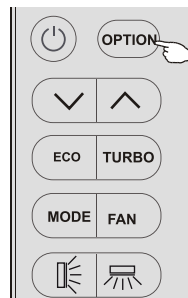

OPERATING INSTRUCTIONS

MILDEW function (Optional)

[MILDEW]

Press [OPTION] at the first time, select the MILDEW by pressing the button \wedge or \vee until symbol MILDEW is flashing; Press [OPTION] again to activate the MILDEW function, and [MILDEW] appears on the display. Do it again to deactivate this function.

This function enable the air conditioner still blow airflow about 15 minutes to dry the indoor inner parts to avoid mildew, when the air conditioner is off.

Note: MILDEW function only available in DRY/COOLING mode

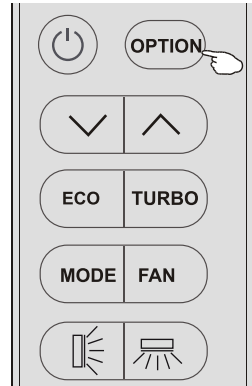

SELF-CLEAN function (Optional)

[CLEAN]

Switch off the air conditioner by pressing

Press [OPTION] at the first time, select the CLEAN by pressing the button \wedge or \vee until symbol CLEAN is flashing; Press [OPTION] again to activate the CLEAN function, and [CLEAN] appears on the display. Do it again to deactivate this function.

1. This function help carry away the accumulated dirt, bacteria, etc from the evaporator.
2. This function will run about 30 minutes, and it will return to the pre-setting mode. You can press \odot to cancel this function during the process. You will hear 2 beeps when it's finished or cancelled.
3. It's normal if there are some noise during this function process, as plastic materials expand with heat and contract with cold.
4. We suggest operate this function as the following ambient condition to avoid certain safety protection features.

Indoor unit	Temp<30°C
Outdoor unit	5°C<Temp<30°C

5. We suggest operate this function per 3 months.

8°C heating function (Optional)

[8°C H]

It can be set in Cool/Heat/Dry/Fan/Auto mode, but you need to turn off the unit to activate it.

1. Press [OPTION] at the first time, select the 8°C H by pressing the button \wedge or \vee until symbol 8°C H is flashing; Press [OPTION] again to choose the 8°C heating function, and [8°C H] appears on the display. Do it again or change the mode to deactivate this function.
2. If the air conditioner is standby, this function enable the air conditioner automatically start heating when the indoor temperature is equal or lower than 8°C, it will return standby if the temperature is equal or higher than 18°C.

PROTECTION

The air conditioner is programmed for comfortable and suitable living conditions, if it is used in abnormal conditions as below, certain safety protection features might come into effect.

For T1 Climate condition models:

No.	MODE	Ambient temperature
1	Heating	Outdoor temperature is over 24°C
		Outdoor temperature is below -7°C
		Room temperature is over 27°C
2	Cooling	Outdoor temperature is over 43°C
		Room temperature is below 21 °C
3	Dry	Room temperature is below 18° C

For Tropical (T3) Climate condition models:

No.	MODE	Ambient temperature
1	Heating	Outdoor temperature is over 24°C
		Outdoor temperature is below -7°C
		Room temperature is over 27°C
2	Cooling	Outdoor temperature is over 52°C
		Room temperature is below 21 °C
3	Dry	Room temperature is below 18° C

 The unit does not operate immediately if it is turned on after being turned off or after changing the mode during operation. this is a normal self-protection action, you need wait for about 3 minutes.

 The capacity and efficiency are according to the test conducted at full-load operation*.
*The highest speed of indoor fan motor and the maximum open angle of the flaps and deflectors are requested.

INSTALLATION MANUAL---Selecting the Installation Place

INDOOR UNIT

- Install the indoor unit on a strong wall that is not subject to vibrations.
- The in let and outlet ports should not be obstructed:the air should be able to blow all over the room.
- Do not install the unit near a source of heat , steam,or flammable gas.
- Install the unit near an electric socket or private circuit.
- Do not install the unit where it will be exposed to direct sunlight.
- Select a site where the condensed water can be easily drained out, and where it is easily connected to outdoor unit.
- Check the machine operation regularly and reserve the necessary spaces as shown in the picture.
- Select a place where the filter can be easily taken out.

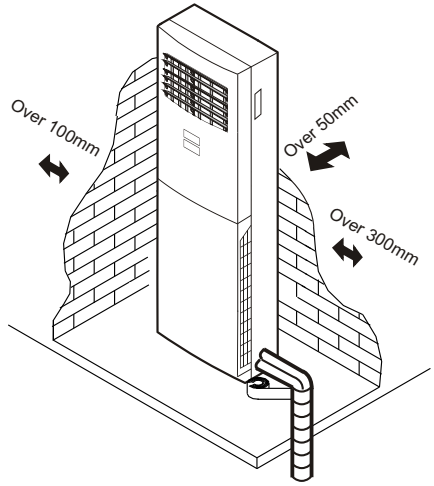

OUTDOOR UNIT

- Do not install the outdoor unit near sources of heat, steam or flammable gas.
- Do not install the unit in too windy or dusty places.
- Do not install the unit where people often pass.Select a place where the air discharge and operating sound will not disturb the neighbours.
- Avoid installing the unit where it will be exposed to direct sunlight (other wise use a protection , if necessary, that should not interfere with the air flow).
- Reserve the spaces as shown in the picture for the air to circulate freely.
- Install the outdoor unit in a safe and solid place.
- If the outdoor unit is subject to vibration, place rubber gaskets onto the feet of the unit..

minimum space to be reserved (mm) showing in the picture

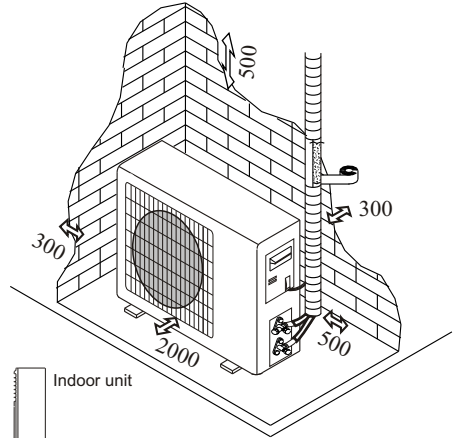

Installation Diagram

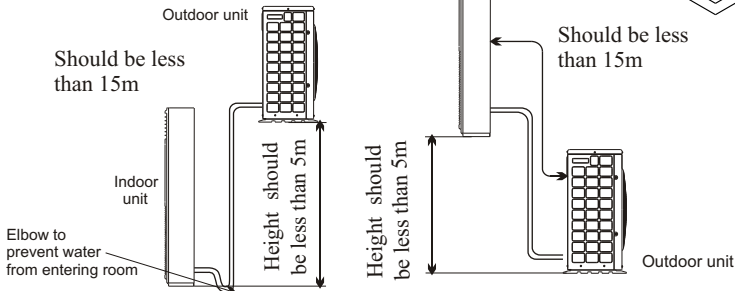

The purchaser must ensure that the person and/or company who is to install, maintain or repair this air conditioner has qualifications and experience in refrigerant products.

INSTALLATION MANUAL---Installation of the Indoor unit

Before starting installation, decide on the position of the indoor and outdoor units, taking into account the minimum space reserved around the units

- ⚠ Do not install your air conditioner in a wet room such as a bathroom or laundry etc

Note : The shape of the mounting plate may be different from the one above, but installation method is similar .

Drilling a hole in the wall for the piping

1. Decide where to drill the hole in the wall for the piping (if necessary) according to the position of the indoor unit;
2. Install a flexible flange through the hole in the wall to keep the latter intact and clean.

- ⚠ The hole must slope downwards towards the exterior

Note : Keep the drain pipe down towards the direction of the wall hole, otherwise leakage may occur.

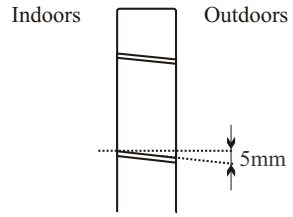

Electrical connections---Indoor unit

1. Take off the front panel as indicated in the picture (by removing the screws)
2. Take out the accessories from the indoor unit.
3. Take off the cover as indicated in the picture (by removing a screw).
4. For the electrical connections, see the circuit diagram on the right part of the unit under the front panel.
5. Connect the cable wires to the screw terminals by following the numbering ,Use wire size suitable to the electric power input (see name plate on the unit) and according to all current national safety code requirements.

- ⚠ The cable connecting the outdoor and indoor units must be suitable for outdoor use.
- ⚠ An efficient earth connection must be ensured.
- ⚠ If the power cable is damaged, it must be replaced by an authorised Service Centre.

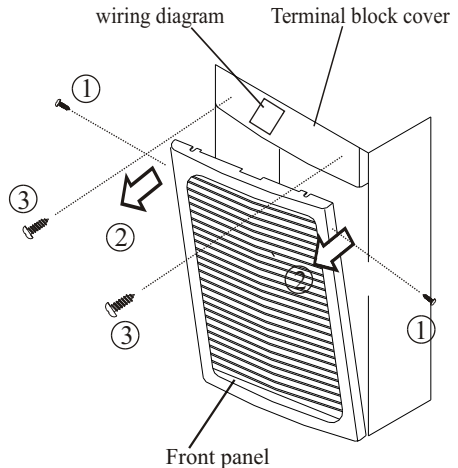

INSTALLATION MANUAL---Installation of the Indoor unit

Refrigerant piping connection

The piping can be run in the 3 directions indicated by numbers in the picture. Select a most suitable one for installation convenience.

Run the piping in the direction of the wall hole and bind the copper pipes, the drain pipe and the power cables together with the tape with the drain pipe at the bottom, so that water can flow freely.

Friendly reminder:

In order to better protect the connecting pipe and the connecting line, the pipe hole sealing component needs to be installed on the pipe hole. The specific installation position is determined according to the actual pipe running direction (left side plate, right side plate, rear plate); after the connecting pipe is installed Fix it with 1 screw, and the specific position can be moved according to the actual situation;

Do not remove the cap from the pipe until connecting it, to avoid dampness or dirt from entering.

If the pipe is bent or pulled too often, it will become stiff. Do not bend the pipe more than three times at one point.

When extending the rolled pipe, straighten the pipe by unwinding it gently as shown in the picture.

Friendly reminder:

In order to facilitate the installation, the thicker connecting pipe of this model (when the indoor side is connected to the rear) needs to have $\geq 375\text{mm}$ thread L. Otherwise, the connecting pipe may bear against the filter net, and there is a problem that the filter is loose or the gap of the lower panel is too large;

Connections to the indoor unit

1. Remove the indoor unit pipe cap (check that there is no debris inside).
2. Insert the flare nut and create a flange at the extreme end of the connection pipe.
3. Tighten the connections by using two wrenches working in opposite directions

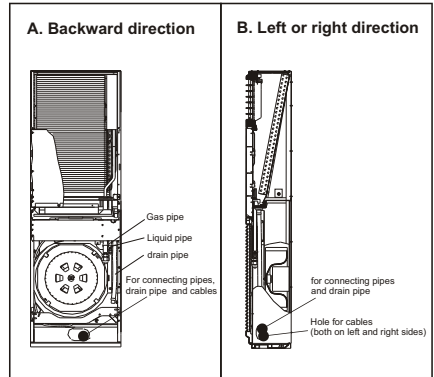

Shape the connection pipe

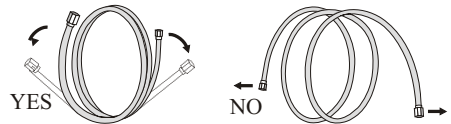
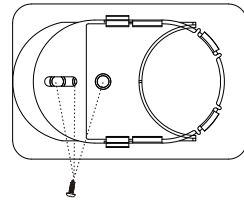

Extending the rolled pipe

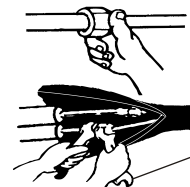
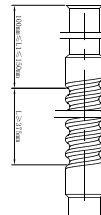

torque wrench

INSTALLATION MANUAL---Installation of the Indoor unit

Indoor unit condensed water drainage

The indoor unit condensed water drainage is fundamental for the success of the installation.

1. Place the drain hose below the piping, taking care not to create siphons.
2. The drain hose must slant downwards to aid drainage.
3. Do not bend the drain hose or leave it protruding or twisted and do not put the end of it in water. If an extension is connected to the drain hose, ensure that it is lagged when it passes into the indoor unit.

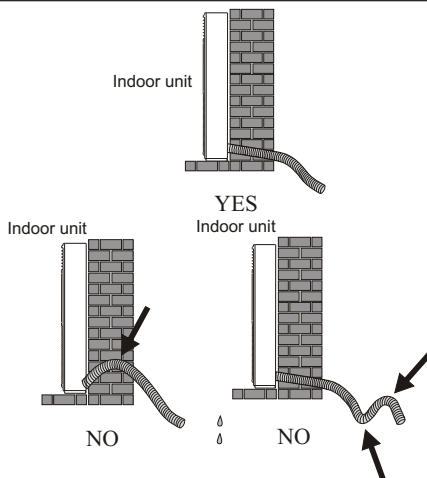

INSTALLATION OF THE INDOOR UNIT

After having connected the pipe according to the instructions, install the connection cables. Now install the drain pipe. After connection, lag the pipe, cables and drain pipe with the insulating material.

1. Arrange the pipes, cables and drain hose well.
2. Lag the pipe joints with insulating material, securing it with vinyl tape.
3. Run the bound pipe, Cables and drain pipe through the wall hole and mount the indoor unit onto the upper part of the mounting plate securely.

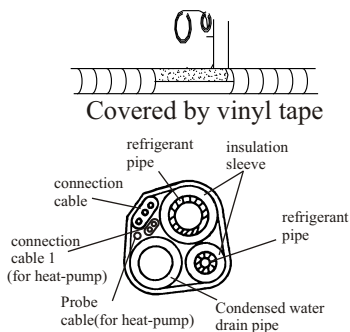

INSTALLATION MANUAL---Installation of the outdoor unit

- The outdoor unit should be installed on a solid wall and fastened securely.
- The following procedure must be observed before connecting the pipes and connecting cables: decide which is the best position on the wall and leave enough space to be able to carry out maintenance easily.
- Fasten the support to the wall using screw anchors which are particularly suited to the type of wall;
- Use a larger quantity of screw anchors than normally required for the weight they have to bear to avoid vibration during operation and remain fastened in the same position for years without the screws becoming loose.
- The unit must be installed following the national regulations.

Outdoor unit condensed water drainage (only for heat pump models)

The condensed water and the ice formed in the outdoor unit during heating operation can be drained away through the drain pipe.

1. Fasten the drain port in the 25mm hole placed in the part of the unit as shown in the picture.
 2. Connect the drain port and the drain pipe.
- Pay attention that water is drained in a suitable place.

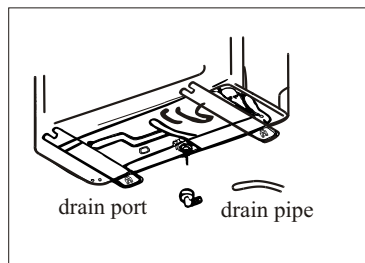

INSTALLATION MANUAL---Installation of the outdoor unit

ELECTRICAL CONNECTIONS

1. Remove the handle on the right side plate of outdoor unit.
2. Connect the power connection cord to the terminal board.
Wiring should fit that of indoor unit.
3. Fix the power connection cord with wire clamp.
4. Confirm if the wire has been fixed properly.
5. An efficient earth connection must be ensured.
6. Recover the handle.

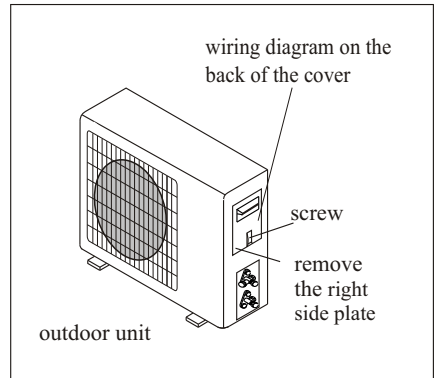

CONNECTING THE PIPES

Screw the flare nuts to the outdoor unit coupling with the same tightening procedures described for the indoor unit.

To avoid leakage, pay attention to the following points:

1. Tighten the flare nuts using two wrenches. Pay attention not to damage the pipes.
2. If the tightening torque is not sufficient, there will probably be some leakage. With excessive tightening torque there will also be some leakage, as the flange could be damaged.
3. The surest system consists in tightening the connection by using a fix wrench and a torque wrench: Please check the torque wrench table.

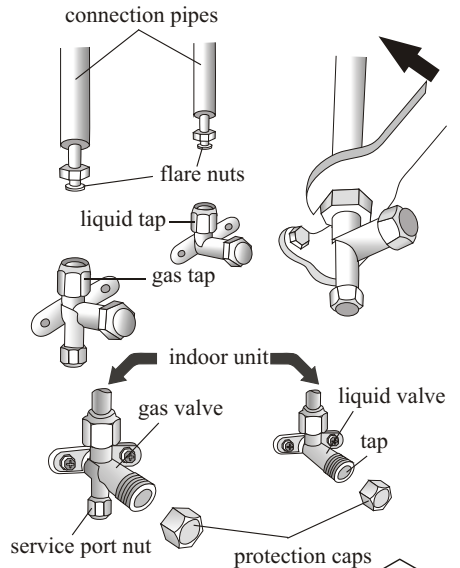

BLEEDING

Air and humidity left inside the refrigerant circuit can cause compressor malfunction. After having connected the indoor and outdoor units, bleed the air and humidity from the refrigerant circuit by using a vacuum pump.

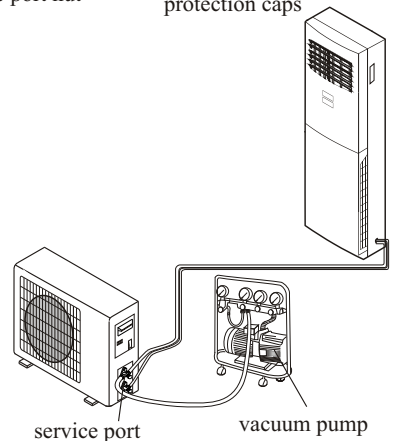

INSTALLATION MANUAL---Installation of the outdoor unit

BLEEDING

The air and humidity left inside the refrigerant circulation can cause compressor malfunction. After having connected the indoor and outdoor units, bleed the air and humidity from the refrigerant circulation using a vacuum pump.

- (1) Unscrew and remove the caps from the 2 - way and 3-way valves.
- (2) Unscrew and remove the cap from the service port.
- (3) Connect the vacuum pump hose to the service port.
- (4) Operate the vacuum pump for 10 - 15 minutes until an absolute vacuum of 10 mm Hg has been reached.
- (5) With the vacuum pump still in operation, close the low - pressure knob on the vacuum pump coupling. Stop the vacuum pump.
- (6) Open the 2 - way valve by 1/4 turn and then close it after 10 seconds. Check all the joints for leaks using liquid soap or an electronic leak device.
- (7) Turn the body of the 2-way and 3-way valves. Disconnect the vacuum pump hose.
- (8) Replace and tighten all the caps on the valves.

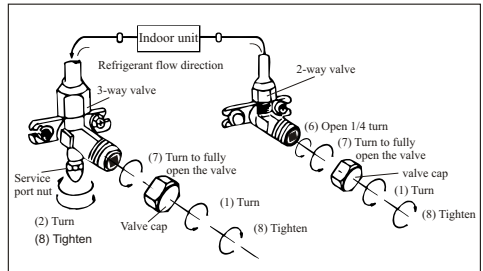
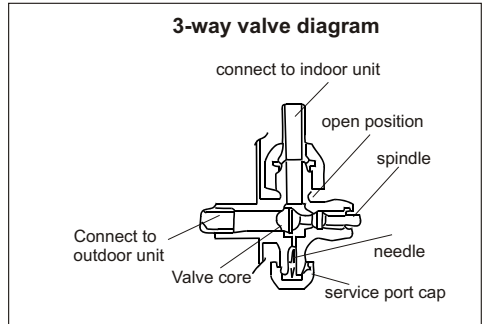

INSTALLATION MANUAL--- operation test

1. Wind insulating covering around the joints of the indoor unit and fix it with insulating tape.
2. Fix the exceeding part of the signal cable to the piping or to the outdoor unit.
3. Fix the piping to the wall (after having coated it with insulating tape) using clamps or insert them into plastic slots.
4. Seal the hole in the wall through which the piping is passed so that no air or water can fill.

Indoor unit test

- Do the ON/OFF and FAN operate normally?
- Does the MODE operate normally?
- Do the set point and TIMER function properly?
- Does each lamp light normally?
- Do the flap for air flow direction operate normally?
- Is the condensed water drained regularly?

Outdoor unit test

- Is there any abnormal noise or vibration during operation?
- Could the noise, the air flow or the condensed water drainage disturb the neighbours?
- Is there any coolant leakage?

Note: the electronic controller allows the compressor to start only three minutes after voltage has reached the system.

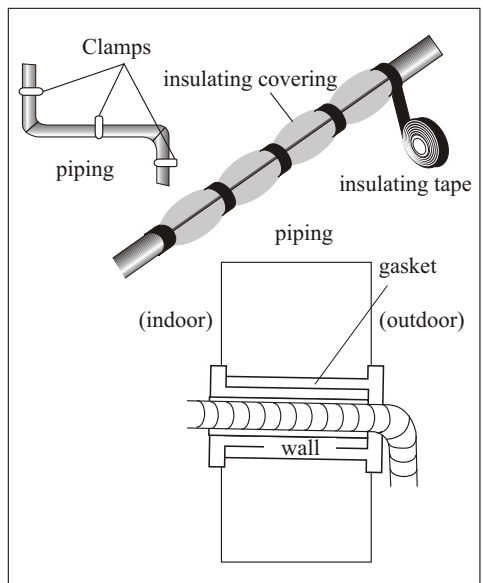

INSTALLATION MANUAL---Information for the installer

MODEL capacity (Btu/h)	18k	24k	36k	42k	48k		
Liquid pipe diameter	1/4 " (φ 6)	3/8 " (φ 9.52)	3/8 " (φ 9.52)	1/2 " (φ 12.70)	1/2 " (φ 12.70)		
Gas pipe diameter	1/2 " (φ 12)	5/8 " (φ 15.88)	5/8 " (φ 15.88)	3/4 " (φ 19.05)	3/4 " (φ 19.05)		
Length of pipe with standard charge	5m	5m	5m	5m	5m		
Maximum distance between indoor and outdoor unit	15m	15m	15m	15m	15m		
Additional refrigerant charge	50g/m	50g/m	50g/m	50g/m	100g/m		
Max. diff. in level between indoor and outdoor unit	5m	5m	5m	5m	5m		
Type of refrigerant(1)							

(1) Refer to the data rating label stucked on the outdoor unit.

*According to model's specification

TIGHTENING TORQUE FOR PROTECTION CAPS AND FLANGE CONNECTION

PIPE	TIGHTENING TORQUE [N x m]	CORRESPONDING STRESS (using a 20 cm wrench)		TIGHTENING TORQUE [N x m]
1/4 " (φ 6)	15 - 20	wrist strength	Service port nut	7 - 9
3/8 " (φ 9.52)	31 - 35	arm strength	Protection caps	25 - 30
1/2 " (φ 12)	35 - 45	arm strength		
5/8 " (φ 15.88)	75 - 80	arm strength		
3/4 " (φ 19.05)	90 - 95	arm strength		

INSTALLATION MANUAL---Information for the installer

WIRING DIAGRAM

For different models, the wiring diagram may be different. Please refer to the wiring diagrams pasted on the indoor unit and outdoor unit respectively.

On indoor unit, the wiring diagram is pasted under the front panel;

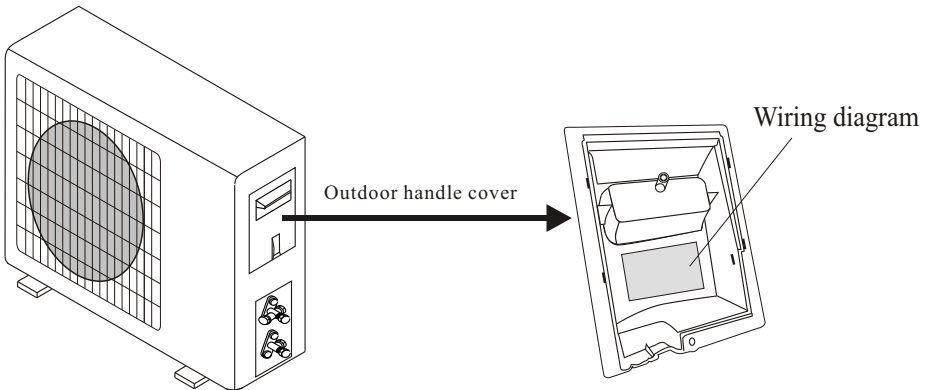
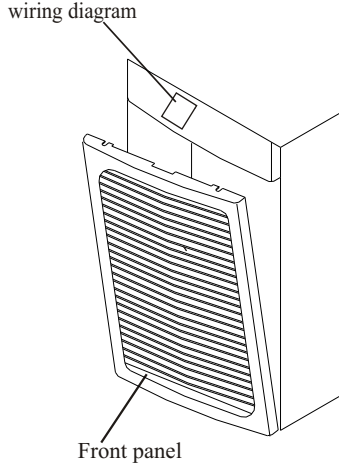

On outdoor unit, the wiring diagram is pasted on the backside of the outdoor handle cover.



Note: For some models the wires has been connected to the main PCB of indoor unit by manufacturer without terminal block.

INSTALLATION MANUAL---Information for the installer

CABLE WIRES SPECIFICATION

MODEL capacity (Btu/h)		18k	24k	36k	42k	48k
		Sectional area				
Power supply cable	N	2.5mm ² AWG12	2.5mm ² AWG12	2.5mm ² (4.0mm ²)	—	0.75mm ² (1.5mm ²)
	L	2.5mm ² AWG12	2.5mm ² AWG12	2.5mm ² (4.0mm ²)	—	0.75mm ² (1.5mm ²)
	E 	2.5mm ² AWG12	2.5mm ² AWG12	2.5mm ² (4.0mm ²)	—	0.75mm ² (1.5mm ²)
	R(A)	—	—	—	2.5mm ² AWG12	2.5mm ² AWG12
	S(B)	—	—	—	2.5mm ² AWG12	2.5mm ² AWG12
	T(C)	—	—	—	2.5mm ² AWG12	2.5mm ² AWG12
	N	—	—	—	2.5mm ² AWG12	2.5mm ² AWG12
		—	—	—	2.5mm ² AWG12	2.5mm ² AWG12
Connection supply cable	N	1.5mm ²	2.5mm ²	0.75mm ² (1.5mm ²)	0.75mm ² (1.5mm ²)	—
	L	—	2.5mm ²	0.75mm ² (1.5mm ²)	0.75mm ² (1.5mm ²)	—
		1.5mm ²	2.5mm ²	0.75mm ² (1.5mm ²)	0.75mm ² (1.5mm ²)	—
	1	1.5mm ²	0.75mm ² (2.5mm ²)	0.75mm ²	0.75mm ²	0.75mm ²
	2	0.75mm ²	0.75mm ² (2.5mm ²)	0.75mm ²	0.75mm ²	0.75mm ²
	3	0.75mm ²	0.75mm ² (2.5mm ²)	0.75mm ²	0.75mm ²	0.75mm ²
	4	—	—	0.75mm ²	0.75mm ²	0.75mm ²

Type of fuse used on indoor unit controller is 50T with rating 5 A , 250V

MAINTENANCE

Periodic maintenance is essential for keeping your air conditioner efficient.

Before carrying out any maintenance, disconnect the power supply by putting the installation on/ off switch to “off” .

INDOOR UNIT

ANTIDUST FILTERS

1. Open the front panel as indicated in the picture (by removing the screws)
2. Keeping the front panel raised with one hand, take out the air filter with the other hand
3. Clean the filter with water; if the filter is soiled with oil, it can be washed with warm water (not exceeding 45°C).
Leave to dry in a cool and dry place.
4. Keeping the front panel raised with one hand, insert the air filter with the other hand
5. Close

The electrostatic and the deodorant filter (if installed) cannot be washed or regenerated and must be replaced with new filters once every 6 months.

CLEANING THE HEAT EXCHANGER

1. Take off the front panel by removing the screws to make the cleaning easier.
2. Clean the indoor unit using a cloth with the water (not higher than 40°C) and neutral soap. Never use aggressive solvents or detergents.

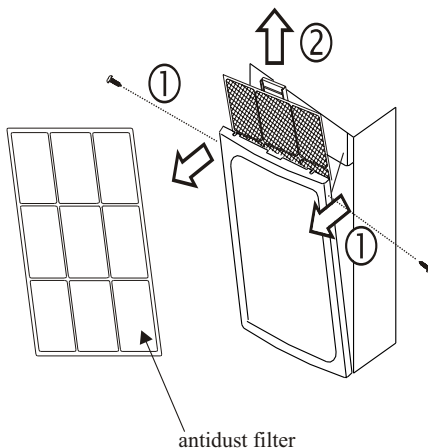

END OF SEASON MAINTENANCE

1. Disconnect the automatic switch or the plug.
2. Clean and replace the filters
3. On a sunny day let the conditioner work in ventilation for some hours, so that the inside of the unit can dry completely..

REPLACING THE BATTERIES

When:

- There is no confirmation beep from the indoor unit.
- The LCD doesn't activate.

How:

- Take off the cover at back.
- Place the new batteries respecting the symbols + and - .

N.B: Use only new batteries. Remove the batteries from the remote control when the conditioner is not in operation

WARNING! Do not throw batteries into common rubbish, they should be disposed of in the special containers situated in the collection points.

TROUBLESHOOTING

MALFUNCTION	POSSIBLE CAUSES	
The appliance does not operate	Power failure/plug pulled out	
	Damaged indoor/outdoor unit fan motor	
	Faulty compressor thermomagnetic circuit breaker	
	Faulty protective device or fuses.	
	Loose connections or plug pulled out	
	It sometimes stops operating to protect the appliance.	
	Voltage higher or lower than the voltage range	
	Active TIMER-ON function	
Strange odour	Air filter dirty	
Noise of running water	Back flow of liquid in the refrigerant circulation	
A fine mist comes from the air outlet	This occurs when the air in the room becomes very cold, for example in the “COOLING” or “DEHUMIDIFYING/DRY” modes.	
A strange noise can be heard	This noise is made by the expansion or contraction of the front panel due to variations in temperature and does not indicate a problem.	
Insufficient airflow, either hot or cold	Inappropriate temperature setting..	
	Air inlet or outlet of indoor or outdoor unit has been blocked.	
	Air filter is blocked.	
	Fan speed set at minimum.	
	Other sources of heat in the room.	
The appliance does not respond to commands	No refrigerant.	
	Remote control is not near enough to indoor unit.	
	Battery in Remote controller may have been exhausted..	
The display is off	Obstacles between remote control and signal receiver in indoor unit.	
	Active LED function	
	Power failure	
Switch off the air conditioner immediately and cut off the power supply in the event of:		
Strange noises during operation.		
Faulty electronic control board		
Faulty fuses or switches.		
Spraying water or objects inside the appliance.		
Overheated cables or plugs.		
Very strong smells coming from the appliance.		
ERROR SIGNALS ON THE DISPLAY		
In case of error, the display on the indoor unit shown the following error codes:		
	RUN lamp	Description of the trouble
<i>E1</i>	flashes once	The fault of indoor temperature sensor
<i>E2</i>	flashes twice	The fault of indoor pipe temperature sensor
<i>E5</i>	flashes 5 times	The protect of outdoor discharge temperature or wrong electrical connections or high current or high pressure



**The widest service center network in the country with
more than 200 outlets**



**Dawlance Reliable service is available for all
household products
Services at your doorstep within 24 hours
Call Center Services available
all week 24/7**

Service UAN # 021-111-11-7359 (RELY)

**Head Office: Dawlance Center 7/4, Civil Lines-9
Dr. Ziauddin Ahmed Road, Karachi.**

Ph: (021) 35652450-9

E-mail: customer.service@dawlance.com.pk

Website: www.dawlance.com.pk

ڈاؤلینس ریلائبل ہے!